

# Bundaberg Flow Reception Counter

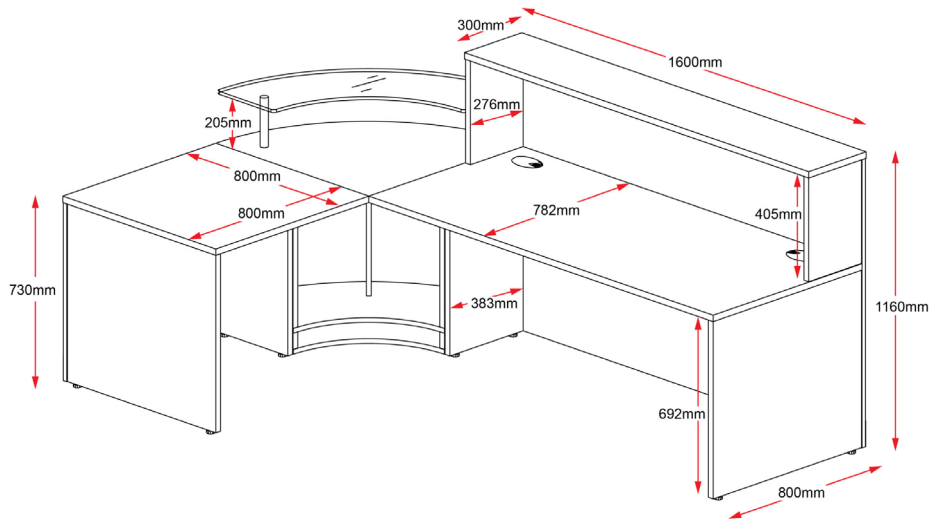

## Product Features:

- Flexible configuration
- Glass feature
- E0 rated melamine board
- Suits large reception areas
- 3 pieces allowing a full height unit at the front
- Glass top corner unit and return

fitting either side

- Traditional finish with beech melamine and silver kick plate

**Warranty: 5 years**

Code	Height	Width	Depth
332500	2400mm	160mm	800mm